

50 Hz, 1500 rpm

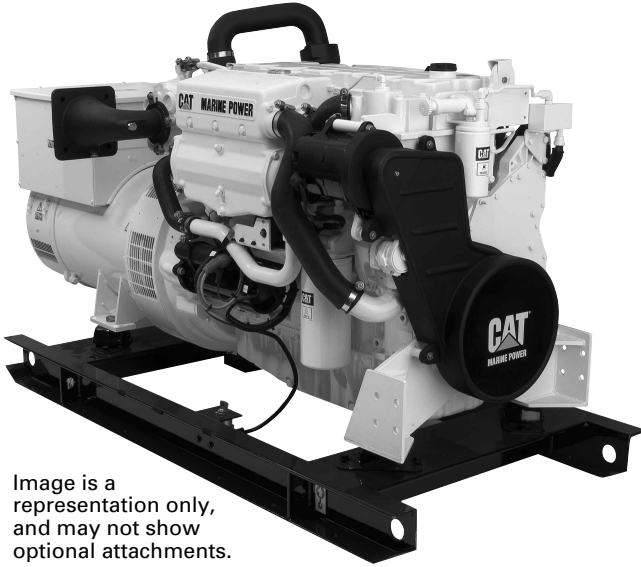

Image is a representation only, and may not show optional attachments.

CATERPILLAR® ENGINE SPECIFICATIONS

I-6, 4-Stroke-Cycle-Diesel

Emissions	IMO/EPA Tier 2 compliant
Displacement	8.8 L (538 cu. in.)
Rated Engine Speed	1500
Bore	112 mm (4.41 in.)
Stroke	149 mm (5.87 in.)
Aspiration	Turbocharged-Aftercooled
Governor	Electronic
Cooling System	Radiator
Refill Capacity	
Cooling System	47.5 L (50.1 qt)
Lube Oil System	32 L (33.8 qt)
Oil Change Interval	500 hr
	Caterpillar Diesel Engine Oil 10W30 or 15W40
Rotation (from flywheel end)	Counterclockwise
Flywheel and flywheel housing	SAE No. 1
Flywheel Teeth	113
Max. Exhaust Backpressure	10.0 kPa (40.2 in. water)

STANDARD EQUIPMENT

Air Inlet System

Aftercooler, air cleaner, turbocharger

Control System

Electronic governor, Hydraulically actuated Electronically controlled Unit Injection (HEUI™) fuel system, Electronic Control Unit (ECU), engine-mounted 40-pin dedicated customer connector, SAE J1939 data link

Cooling System

Radiator-cooled package (sized for up to 50°C ambient air) incorporating deaeration expansion tank, belt-driven centrifugal jacket water pump and fan

Exhaust System

Manifold and turbocharger, watercooled; 152 mm (6 in) round flanged outlet; elbow, dry

Flywheels & Flywheel Housings

Flywheel, SAE No. 1, 113 teeth; flywheel housing, SAE No. 1

Fuel System

Fuel filter, front service; fuel transfer pump; fuel priming pump

Generator

12 lead reconnectable, 3-phase brushless, separately excited from auxiliary winding to provide 300% short circuit current up to 10 seconds, 2/3 pitch, broad voltage band, IP23 water protection, solid state voltage regulator with integral voltage adjustment, Class H insulation, generator temperature rise exceeds marine society requirements for Class H insulation, 105° C @ 50° C ambient — prime, 85° C @ 50° C ambient — prime connection poles

Instrumentation

Instrument panel, electric service meter, start/stop switch, emergency stop button, maintenance due light, diagnostic light, warning light, maintenance clear switch, 15A breaker

Lube System

Crankcase breather; oil filter, RH service; oil filler, in valve cover; oil level gauge, LH service; oil pan; oil pan drain, LH; lubricating oil; engine oil pump (gear-driven)

Mounting System

Skiddable base frame, front support, anti-vibration isolators between base and engine-generator

General

Torsional vibration damper and guard; paint, Caterpillar yellow; lifting eyes; protective lifting covers; literature; variable engine wiring; battery disconnect switch; plastic wrap packaging

OPTIONAL ATTACHMENTS

Exhaust System

Elbows, pipe, flexible fittings, flange, rain caps, mufflers, shields (shields required to meet MCS certification)

Fuel System

Fuel cooler, flexible fuel lines, fuel temperature sensors, fuel and oil shielding

Lube System

Manual sump pumps, oil filler, duplex oil filters

Marine Classification Society (MCS)

MCS approvable packages available direct from the factory through ABS, BV, DNV, GL, and LR

Power Take-offs

Crankshaft pulley

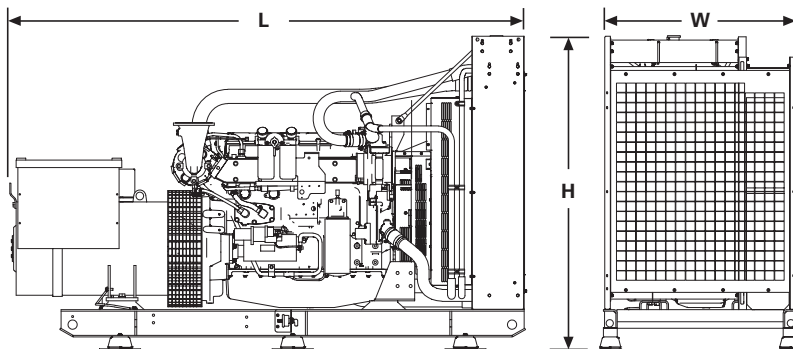

DIMENSIONS

142 ekW (178 kVA), 167 ekW (208 kVA), and 192 ekW (240 kVA) Radiator-Cooled

Length	142 ekW (178 kVA)	2755 mm (108.5 in)
	167 & 192 ekW (208 & 240 kVA)	2765 mm (108.7 in)
Width	All	1047 mm (41.2 in)
Height	All	1615 mm (63.6 in)
Weight (wet)	142 ekW (178 kVA)	2091 kg (4610 lb)
	167 ekW (208 kVA)	2176 kg (4797.3 lb)
	192 ekW (240 kVA)	2241 kg (4940.6 lb)
Weight (wet) MCS Specification	142 ekW (178 kVA)	2100 kg (4620 lb)
	167 ekW (208 kVA)	2185 kg (4807 lb)
	192 ekW (240 kVA)	2250 kg (4950 lb)

PERFORMANCE DATA

50 Hz Ratings at 1800 rpm

% load	ekW	Lph	gph
142 ekW (0.8 pf) 178 kVA — DM9841			
100	142	41.6	10.8
75	106	31.3	8.3
167 ekW (0.8 pf) 208 kVA — DM9842			
100	167	47.1	12.4
75	124	36.2	9.6
192 ekW (0.8 pf) 240 kVA — DM9839			
100	192	53.7	14.2
75	144	40.8	10.8

RATING CONDITIONS

Power at declared engine speed is in accordance with ISO3046-1:2002E. Caterpillar maintains ISO9001:1994/QS-9000 approved engine test facilities to assure accurate calibration of test equipment. Electronically controlled engines are set at the factory at the advertised power corrected to standard ambient conditions. The published fuel consumption rates are in accordance with ISO3046-1:2002E.

Fuel rates are based on fuel oil of 35° API [16°C (60°F)] gravity having an LHV of 42 780 kJ/kg (18,390 Btu/lb) when used at 29°C (85°F) and weighing 838.9 g/L (7.001 lb/U.S. gal). Additional ratings may be available for specific customer requirements. Consult your Caterpillar representative for additional information.

Performance data is calculated in accordance with tolerances and conditions stated in this specification sheet and is only intended for purposes of comparison with other manufacturers' engines. Actual engine performance may vary according to the particular application of the engine and operating conditions beyond Caterpillar's control.

Power produced at the flywheel will be within standard tolerances up to 49°C (120°F) combustion air temperature measured at the air cleaner inlet, and fuel temperature up to 52°C (125°F) measured at the fuel filter base. Power rated in accordance with NMMA procedure as crankshaft power. Reduce crankshaft power by 3% for propeller shaft power.

CAT, CATERPILLAR, their respective logos, HEUI, "Caterpillar Yellow" and the POWER EDGE trade dress, as well as corporate and product identity used herein, are trademarks of Caterpillar and may not be used without permission.

60 Hz, 1800 rpm

CATERPILLAR® ENGINE SPECIFICATIONS

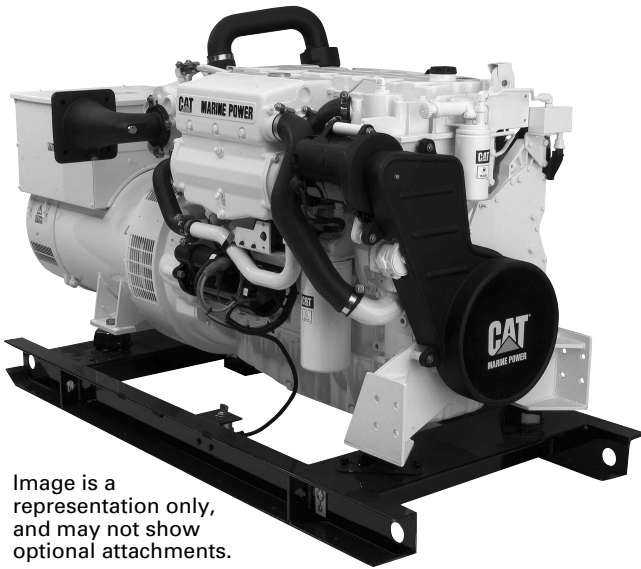

Image is a representation only, and may not show optional attachments.

I-6, 4-Stroke-Cycle-Diesel

Emissions	IMO/EPA Tier 2 and CCNR Stage II compliant
Displacement	8.8 L (538 cu. in.)
Rated Engine Speed	1800
Bore	112 mm (4.41 in.)
Stroke	149 mm (5.87 in.)
Aspiration	Turbocharged-Aftercooled
Governor	Electronic
Cooling System	Radiator
Refill Capacity	
Cooling System	47.5 L (50.1 qt)
Lube Oil System	32 L (33.8 qt)
Oil Change Interval	500 hr
Caterpillar Diesel Engine Oil	10W30 or 15W40
Rotation (from flywheel end)	Counterclockwise
Flywheel and flywheel housing	SAE No. 1
Flywheel Teeth	113
Max. Exhaust Backpressure	10.0 kPa (40.2 in. water)

STANDARD EQUIPMENT

Air Inlet System

Aftercooler, air cleaner, turbocharger

Control System

Electronic governor, Hydraulically actuated Electronically controlled Unit Injection (HEUI™) fuel system, Electronic Control Unit (ECU), engine-mounted 40-pin dedicated customer connector, SAE J1939 data link

Cooling System

Radiator-cooled package (sized for up to 50°C ambient air) incorporating deaeration expansion tank, belt-driven centrifugal jacket water pump and fan

Exhaust System

Manifold and turbocharger, watercooled; 152 mm (6 in) round flanged outlet; elbow, dry

Flywheels & Flywheel Housings

Flywheel, SAE No. 1, 113 teeth; flywheel housing, SAE No. 1

Fuel System

Fuel filter, front service; fuel transfer pump; fuel priming pump

Generator

12 lead reconnectable, 3-phase brushless, separately excited from auxiliary winding to provide 300% short circuit current up to 10 seconds, 2/3 pitch, broad voltage band, IP23 water protection, solid state voltage regulator with integral voltage adjustment, Class H insulation, generator temperature rise exceeds marine society requirements for Class H insulation, 105° C @ 50° C ambient — prime, 85° C @ 50° C ambient — prime connection poles

Instrumentation

Instrument panel, electric service meter, start/stop switch, emergency stop button, maintenance due light, diagnostic light, warning light, maintenance clear switch, 15A breaker

Lube System

Crankcase breather; oil filter, RH service; oil filler, in valve cover; oil level gauge, LH service; oil pan; oil pan drain, LH; lubricating oil; engine oil pump (gear-driven)

Mounting System

Skiddable base frame, front support, anti-vibration isolators between base and engine-generator

General

Torsional vibration damper and guard; paint, Caterpillar yellow; lifting eyes; protective lifting covers; literature; variable engine wiring; battery disconnect switch; plastic wrap packaging

OPTIONAL ATTACHMENTS

Exhaust System

Elbows, pipe, flexible fittings, flange, rain caps, mufflers, shields (shields required to meet MCS certification)

Fuel System

Fuel cooler, flexible fuel lines, fuel temperature sensors, fuel and oil shielding

Lube System

Manual sump pumps, oil filler, duplex oil filters

Marine Classification Society (MCS)

MCS approvable packages available direct from the factory through ABS, BV, DNV, GL, and LR

Power Take-offs

Crankshaft pulley

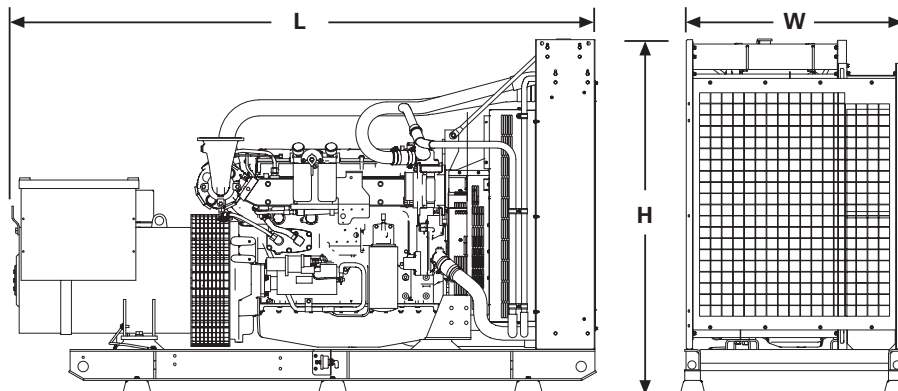

DIMENSIONS

163 ekW (204 kVA), 203 ekW (254 kVA), and 238 ekW (298 kVA) Radiator-Cooled

Length	163 ekW (204 kVA)	2755 mm (108.5 in)
	203 & 238 ekW (254 & 298 kVA)	2765 mm (108.7 in)
Width	All	1047 mm (41.2 in)
Height	All	1615 mm (63.6 in)
Weight (wet)	163 ekW (204 kVA)	2091 kg (4610 lb)
	203 ekW (254 kVA)	2176 kg (4797.3 lb)
	238 ekW (298 kVA)	2241 kg (4940.6 lb)
Weight (wet) MCS Specification	163 ekW (204 kVA)	2100 kg (4620 lb)
	203 ekW (254 kVA)	2185 kg (4807 lb)
	238 ekW (298 kVA)	2250 kg (4950 lb)

PERFORMANCE DATA

60 Hz Ratings at 1800 rpm

% load	ekW	Lph	gph
163 ekW (0.8 pf) 204 kVA — DM9843			
100	163	51.6	13.6
75	122	39.8	10.5
203 ekW (0.8 pf) 254 kVA — DM9844			
100	203	63.5	16.8
75	152	47.6	12.6
238 ekW (0.8 pf) 298 kVA — DM9845			
100	238	68.1	17.9
75	178	51.4	13.6

RATING CONDITIONS

Power at declared engine speed is in accordance with ISO3046-1:2002E. Caterpillar maintains ISO9001:1994/QS-9000 approved engine test facilities to assure accurate calibration of test equipment. Electronically controlled engines are set at the factory at the advertised power corrected to standard ambient conditions. The published fuel consumption rates are in accordance with ISO3046-1:2002E.

Fuel rates are based on fuel oil of 35° API [16°C (60°F)] gravity having an LHV of 42 780 kJ/kg (18,390 Btu/lb) when used at 29°C (85°F) and weighing 838.9 g/L (7.001 lb/U.S. gal). Additional ratings may be available for specific customer requirements. Consult your Caterpillar representative for additional information.

Performance data is calculated in accordance with tolerances and conditions stated in this specification sheet and is only intended for purposes of comparison with other manufacturers' engines. Actual engine performance may vary according to the particular application of the engine and operating conditions beyond Caterpillar's control.

Power produced at the flywheel will be within standard tolerances up to 49°C (120°F) combustion air temperature measured at the air cleaner inlet, and fuel temperature up to 52°C (125°F) measured at the fuel filter base. Power rated in accordance with NMMA procedure as crankshaft power. Reduce crankshaft power by 3% for propeller shaft power.

CAT, CATERPILLAR, their respective logos, HEUI, "Caterpillar Yellow" and the POWER EDGE trade dress, as well as corporate and product identity used herein, are trademarks of Caterpillar and may not be used without permission.